



EAU VATION®



BOILING



CHILLED



SPARKLING



HOT & COLD

MULTIFUNCTION TAPS >

## TOUCH™

—One tap, five functions

### SPECIAL FEATURES

- Delivers high volumes of boiling, chilled, sparkling, hand hot\* and hand cold water *\*requires separate hot water supply*
- Fits into a standard 600mm cabinet
- No ventilation required
- Lowest energy consumption
- Highest performing insulation
- Most robust and reliable system on the market
- 24 month unlimited\*\* warranty, excludes misuse or abuse

*\*\*subject to annual service*

Call 0844 225 9250 to book an installation  
or find out more at [Eauvation.co.uk](http://Eauvation.co.uk)

MADE  
IN GREAT  
BRITAIN 

riba  
product  
selector

n55Plus

MULTIFUNCTION TAPS >

# TOUCH™

—One tap, five functions



Model: Q553 BCS

Demand more than just boiling, insist on Touch™ the only 5 function touchscreen tap.

Touch is the most stylish and technologically advanced multifunction tap on the market. Its touch screen control panel dispenses boiling, chilled, sparkling, hot and cold filtered water as standard, or as pure water, with an upgrade to our SmartRO water purifier.

Manufactured and assembled in Great Britain using the highest quality components chosen for proven strength and longevity with low environmental impact, aiding clients meet their corporate social responsibilities.

The under sink or under cabinet system offers the choice of filtered or pure\* boiling, chilled, still and sparkling water modules as well as ambient water. The under counter unit incorporates easy to install and maintain quick fit filters and CO2 cartridges as well as \*multimedia filters to reduce impurities found in mains fed water.

### TOUCH™ (left)

Model shown provides Pure\* boiling, chilled and sparkling water and mains hot and cold water in polished stainless steel finish.

## FEATURES AND BENEFITS

### BOILER FUNCTION

Illuminated control with built in safety function.

Delivering 3ltr instant draw and 30ltr/hr without temperature loss.

### CHILLED WATER FUNCTION

Illuminated control.

Chiller delivers up to 100ltr/hr at 5 degrees with no temperature gain. No limit on use.

### SPARKLING WATER FUNCTION

Illuminated control.

No limit to capacity – keeps on delivering without the typical airlocks found in other systems.

### \*PURE WATER FUNCTION

The only system suitable for use with optional RO water for the ultimate in taste and purity.

### HOT & COLD WATER

Saves water by dispensing mains tap water at the perfect pre-set temperature for rinsing and washing.

### BUILD QUALITY

Tank and element are made from 316 stainless steel, the best material for water, giving the strongest, longest lasting system on the market.

### ENERGY EFFICIENT

33% less energy used than a kettle, with quicker recovery time.

### PERFORMANCE

Thermal insulation outperforms any other boiler design on the market. Silent running pump for quiet production of sparkling water. Adjustable setting for sparkling and chilled temperature.



Model: Q553 BCS

### TOUCH™

fits seamlessly on to any counter top in food preparation areas in kitchens, restaurants and offices. The touchscreen angles for ease of use. Model shown in polished stainless steel, brushed stainless steel finish also available.

### DIMENSIONS

Note: All dimensions in mm

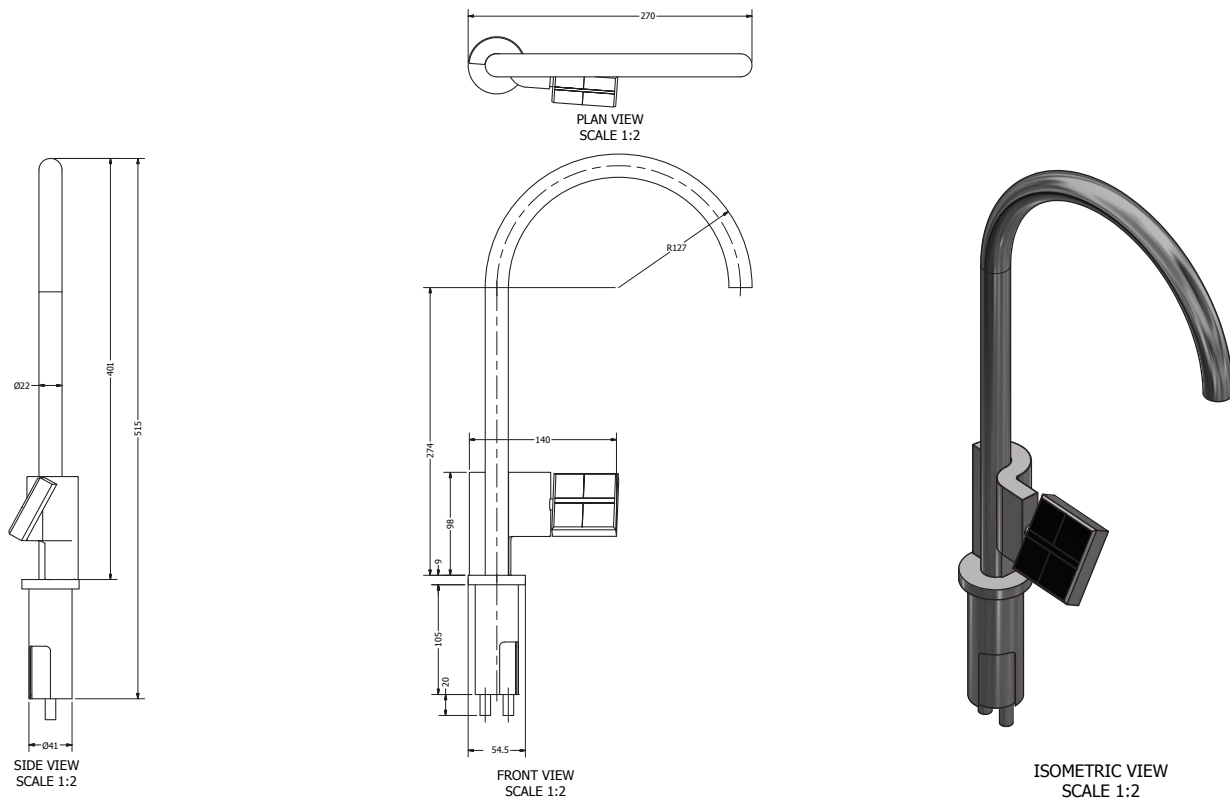

### HYDROCELL 553 DIMENSIONS

### HYDROCELL CHILLER CARBONATOR H553CS DIMENSIONS

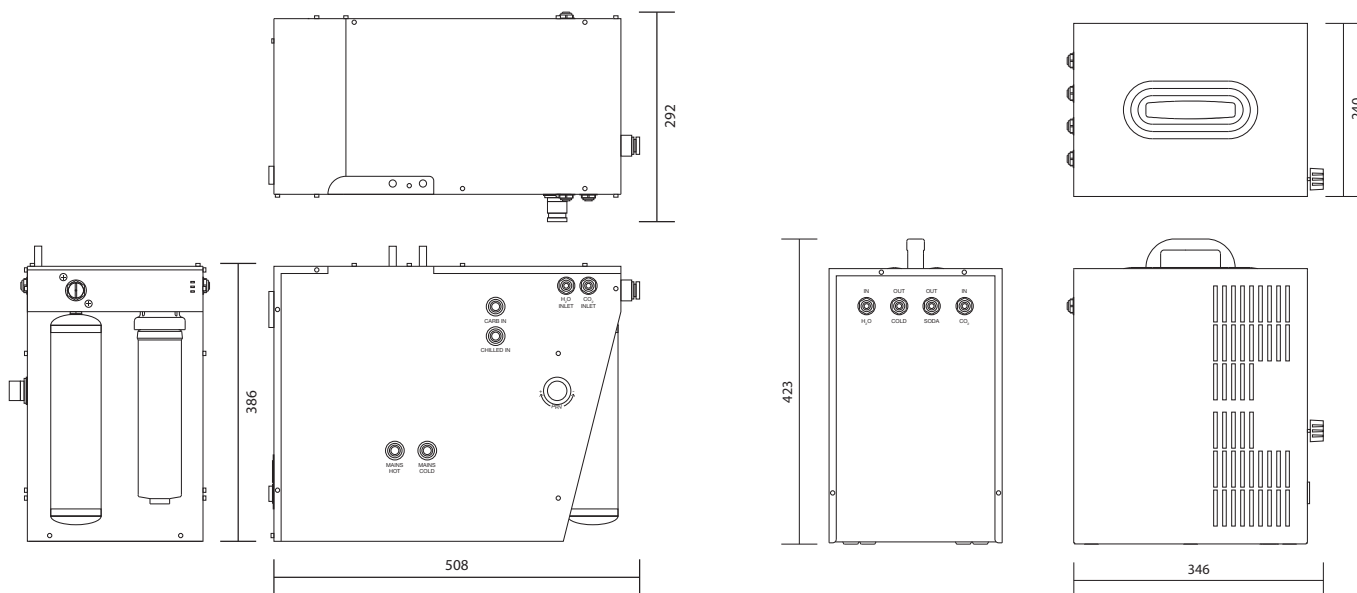

Typical installation of under counter systems for delivery of boiling, chilled, sparkling, hand hot and hand cold water

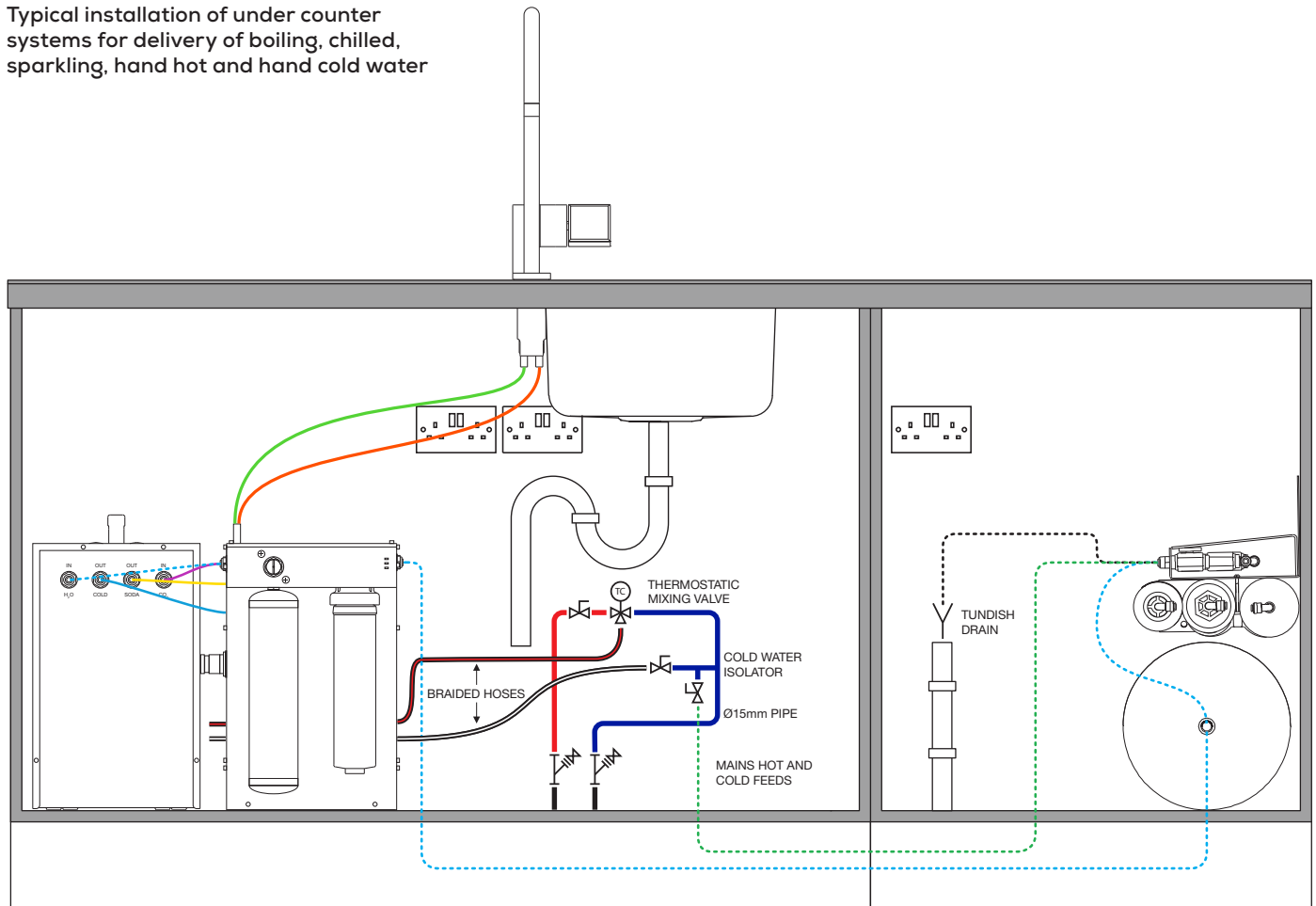

### SPECIFICATION

#### PRODUCTION RATES

QT-553CS-50

Chilled sparkling: 50 ltr/hr capacity with chilled water blanket if required  
Boiling: approx. 30 ltr/hr at 98° C

QT-553CS-100

Chilled sparkling: 100 ltr/hr capacity with chilled water blanket if required  
Boiling: approx. 30 ltr/hr at 98° C

#### SITE PREPARATION

- A template is provided for tap panel cut out.
- Tap panel may be sited behind the sink or alongside to the left or right hand side.
- Tap panel will be produced to suit client's choice of orientation.

#### Requirements:

- 1 x (15mm lever ball valve or equivalent) isolated cold water mains.
- 1 x Double 13amp SSO.

#### TECHNICAL DETAIL

##### HYDROCELL 553

POWER	13A Double SSO or fused spur
VOLTAGE	230V
WATTAGE	Max 2.56KW Standby 80W
START UP TIME	8 minutes
MAX PRESSURE	50psi
CO2 CAPACITY	n/a

##### CHILLER / CHILLER-CARBONATOR H552CS

POWER	13A Double SSO or fused spur
VOLTAGE	230V/230V
WATTAGE	Max 130W/296W Standby 130W/100W
START UP TIME	2hrs/2hrs
MAX PRESSURE	80psi/80psi
CO2 CAPACITY	dependant on cylinder used

#### ANNUAL SERVICE

Servicing and replacing the exhausted components every 12 months keeps your system fully optimised so you'll enjoy the great taste and benefits of pure water day in, day out, and be assured of the \*RODI REMOVAL RATES.

#### Extended warranty

Simply service your system annually to receive free extended warranty for a further 12 months (a fully comprehensive service plan option is then available).

It is not recommended customers install or carry out any repairs to their system.

For further information and to see the full range of purifiers, softeners and multifunction taps visit [Eauvation.co.uk](http://Eauvation.co.uk)